

FLOWIRL™ 8400

Vortex Flowmeter

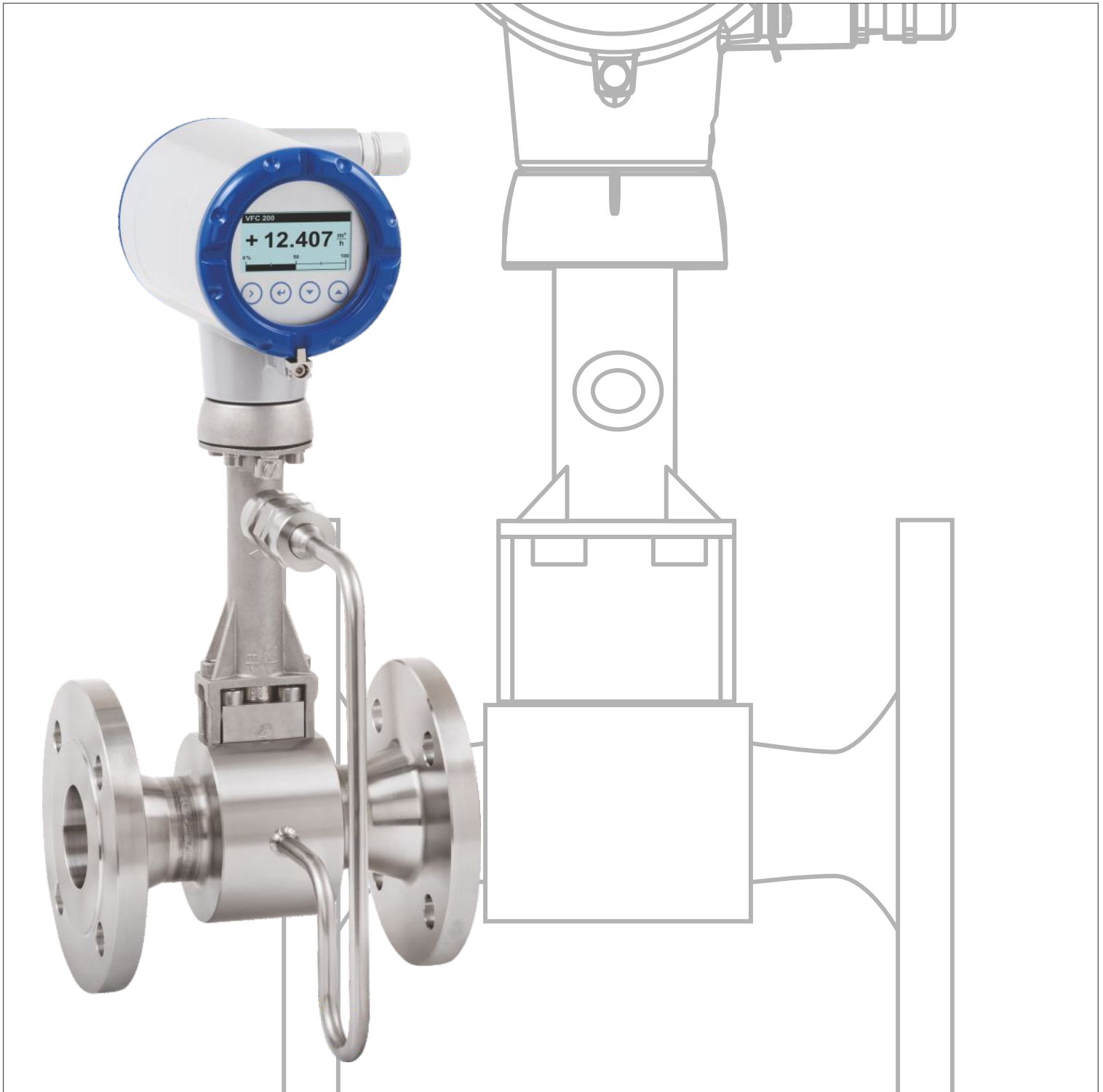

Flowirl™ 8400

The FLOWIRL™ 8400 is suitable for a wide range of media. This versatile vortex flowmeter is capable of mastering fluctuating pressures and temperatures and is the ideal choice for measurement of energy carriers in auxiliary and supply processes.

The basic version is equipped with temperature compensation for saturated steam applications. The optional pressure sensor provides for an integrated density compensation which provides exact measurement of gases and superheated steam even in varying process conditions.

The additional integrated gross and net heat measurement makes this flowmeter a reliable partner for advanced energy management systems.

The All-in-one Solution

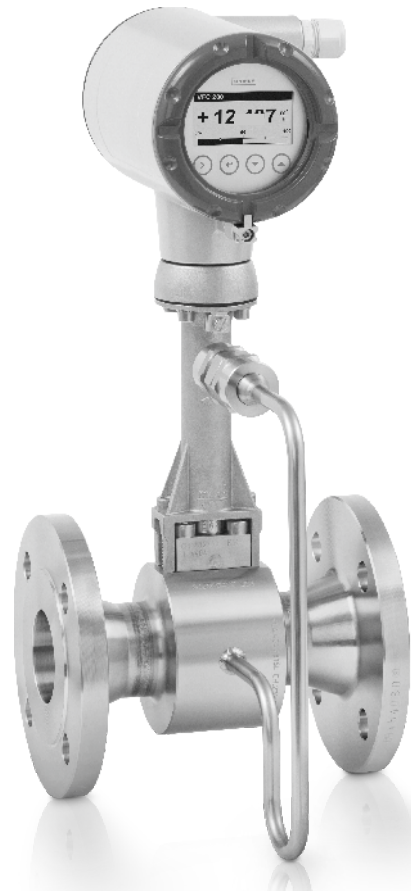

Features

- Advanced technology for signal filtering - AVFD (advanced vortex frequency detection)
- Integrated pressure and temperature compensation
- Temperature compensation for saturated steam included as standard
- Remote version with field housing converter with cable length up to 50 m / 164 ft
- Integrated reduction of nominal size
- Measurement of conductive and non-conductive liquids, gases and steam

Applications

- Measurement of saturated steam and superheated steam
- Steam boiler monitoring
- Measurement of consumption of industrial gases
- Measurement of consumption in compressed air systems
- Monitoring of compressor output
- Evaluation of free air delivery (FAD)
- SIP and CIP processes in the food, beverage and pharmaceutical industries

Functional Principle

Vortex flowmeters are used to measure the flow of gases, vapours and liquids at completely filled pipes.

The measuring principle is based on the Karman vortex street. The measuring tube contains a bluff body at which vortex shedding occurs and which is detected by a sensor unit located behind. The frequency f of the vortex shedding is proportional to the flow velocity v . The non-dimensional Stouhal number S describes the relationship between vortex frequency f , width b of the bluff body and the average flow velocity v :

$$f = \frac{S \cdot v}{b}$$

The vortex frequency is recorded at the flow sensor and evaluated at the signal converter.

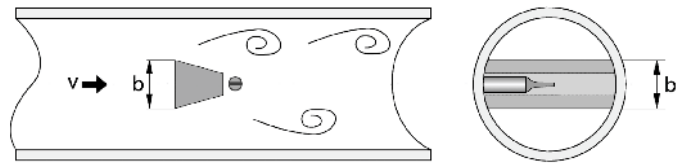

Variants

Standard Version: Universal Device with Temperature Compensation for Saturated Steam

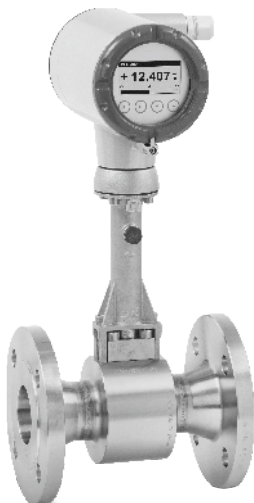

The FLOWIRL™ 8400 as compact flowmeter in a flange version is suitable for universal use in measuring liquids, gases and vapours.

The temperature compensation for saturated steam is integrated as standard, thus enabling direct compensation of density. Mass and energy can also be measured.

The advanced signal filter technology AVFD complements the accurate measurements.

Sandwich Version with Optimised Central Rings



The FLOWIRL™ 8400 as a compact flowmeter in a sandwich version is suitable for universal use in the measurement of liquids, gases and vapours.

The temperature compensation for saturated steam is integrated as standard.

The flowmeter is provided with additional optimised centering rings. It can be aligned centrally by turning the centering rings, eliminating any offset between the flowmeter and the pipeline.

The One-of-a-kind 2-Wire Device with Integrated Pressure and Temperature Compensation



The FLOWIRL™ 8400 as a flange or sandwich flowmeter is optionally available with integrated pressure and temperature compensation for gases, wet gases, gas mixtures or steam.

The advantages of this unique design include

- No additional cost-intensive installation of pressure and temperature sensors

- No additional cabling work

- Direct measurement of mass

- Pressure, temperature and volume flow can be read at a single point, hence no possibility of faulty results

Remote Version



The FLOWIRL™ 8400 is also available as a remote version with field housing converter

This version is suitable in cases where the flow sensor is mounted in inaccessible areas. The signal converter can be installed up to a distance of 50 m / 164 ft from the sensor.

The remote mounted signal converter allows easy operation and reading of values at eye level

In addition to the flow rates, measurements of the integrated pressure and temperature sensors can be displayed

FLOWIRL™ 8400 F1R / F2R with Integrated Nominal Diameter Reduction



The FLOWIRL™ 8400 F1R / F2R with integrated nominal diameter reduction up to two nominal diameter sizes assures best results in accuracy and optimal measuring ranges even in pipelines with large diameters, designed for low pressure loss.

These flowmeters do not require complex pipeline reduction installations, hence save space and cost, and reduce the possibility of leakage to a minimum.

Devices with Integrated Nominal Diameter Reduction

Nominal Diameter of Flow Sensor	Nominal Size of Process Connections									
	DN15	DN25	DN40	DN50	DN80	DN100	DN150	DN200	DN250	DN300
DN15	StV	F1R	F2R	-	-	-	-	-	-	-
DN25	-	StV	F1R	F2R	-	-	-	-	-	-
DN40	-	-	StV	F1R	F2R	-	-	-	-	-
DN50	-	-	-	StV	F1R	F2R	-	-	-	-
DN80	-	-	-	-	StV	F1R	F2R	-	-	-
DN100	-	-	-	-	-	StV	F1R	F2R	-	-
DN150	-	-	-	-	-	-	StV	F1R	F2R	-
DN200	-	-	-	-	-	-	-	StV	F1R	F2R
DN250	-	-	-	-	-	-	-	-	StV	F1R
DN300	-	-	-	-	-	-	-	-	-	StV

StV - Standard Vortex, F1R - Single Reduction, F2R - Double Reduction.

Measuring System

Application Range Flow measurement of liquids, gases and vapours

Function / Measuring Principle Karman vortex street

Measurement

Primary Measured Value Number of separated vortices

Secondary Measured Value Operating and standard volume flow and mass flow

Signal Converter

Versions Compact

Remote version
Cable length: = 50 m / 164 ft

Flow Sensor

Standard Flange version (with integrated temperature measurement), flow sensor: F
Sandwich version (with integrated temperature measurement), flow sensor: S

Option Basic device with additional pressure measurement
Flange version with single reduction of nominal diameter, flow sensor: F1R
Flange version with double reduction of nominal diameter, flow sensor: F2R

Display and User Interface

Local Display Graphic display

Interface and Display Language English

Measuring Accuracy	
Reference Condition	
Reference Conditions	Water at +20°C / +68°F
	Air at +20°C / +68°F and 1.013 bara / 14.7 psia
Maximum Measuring Error	
Volume Flow (Liquid)	±0.75% of measured value (Re = 20000)
Volume Flow	±1.0% of measured value (Re = 20000)
Mass Flow (Gases and Steam)	±1.5% of measured value (Re = 20000)
Mass Flow (Liquid / Water)	±1.5% of measured value (Re = 20000)
Normalised Volume Flow (Gas)	±1.5% of measured value (Re = 20000)
Repeatability (Volume Flow)	±0.1% of measured value

Operating Conditions	
Medium Temperature	-40...+240°C / -40...+465°F
Ambient Temperature	-40...+85°C / -40...+185°F
Storage Temperature	-40...+85°C / -40...+185°F
Pressure	
Medium Pressure	Max. 100 bar / 1450 psi (higher pressures on request)
Ambient Pressure	Atmosphere
Media Properties	
Density	Taken into consideration when sizing
Viscosity	< 10 cP
Reynold's Number	> 1000

Other Conditions	
Ingress Protection	Compact version: IP66/67
	Remote version: signal converter housing: IP66/67; flow sensor housing: IP66/67

Installation Conditions	
Inlet Section	= 15 x DN without disturbing flow, after pipe narrowing, after a single 90° bend
	= 30 x DN after a double bend 2x90°
	= 40 x DN after a double three-dimensional bend 2x90°
	= 50 x DN after control valves
	= 2 DN before flow straightener; = 8 DN after flow straightener
Outlet Section	= 5 x DN

Materials	
Flow Sensor and Process Connections	Standard: 1.4404/316L
Electronics Housing	Aluminium die-cast, two-layer coating (epoxy/polyester)
Pressure Sensor Gasket	FPM
Measuring Tube Gasket (pickup)	Standard: 1.4435/316L

Process Connections of Flange Version	
DIN EN 1092-1	DN15...300 - PN16...100 (higher pressures on request)
ASME B16.5	1/2" ...12" - 150...600 lb (higher pressures on request)
Process Connections of Sandwich Version	
DIN	DN15...100 - PN100 (higher pressures on request)
ASME	1/2" ...4" - 600 lb (higher pressures on request)
Electrical Connections	
Power Supply	12...36 VDC
Inputs and Outputs	
General	All inputs and outputs are electrically isolated from one another.
Time Constant	The time constant corresponds to 63% of the elapsed time of a processor procedure. 0...100 seconds (rounded up to 0.1 seconds)
Current Outputs	
Type	4...20 mA HART® (passive)
Output Data	Volume flow, mass flow, norm. volume flow, free air delivery, density, temperature (internal sensor), pressure, vortex frequency, flow velocity
Resolution	5 µA
Linearity / Accuracy	0.1% (of read value)
Error Signal	According to NE 43
Description of Abbreviations	U _{ext} = external voltage; RL = load + resistance
Load	Minimum RL = 0 Ω; maximum RL = (U _{ext} - 12 VDC) / 22 mA
HART®	
	HART® protocol via passive current output
HART® Revision	HART® 7
	Burst mode
	Catch device
System Requirements	Load min. 250 Ω
Multidrop Operation	4 mA
Binary Output	
Function	Pulse, frequency, status, limit switch
Type	Passive
	Proximity sensor acc. to DIN EN 60947-5-6 (NAMUR sensor) or pulse output signal acc. to VDI/VDE 2188 (category 2)
Pulse	width 0.5...2000 ms
Current Input	
Type	4...20 mA (passive)
Resolution	6 µA
Linearity / Accuracy	0.1% (of read value)
Voltage Drop	10 V
Approvals and Certificates	
IBR	Indian boiler regulation - For steam systems

**Flange Version
Dimensions**

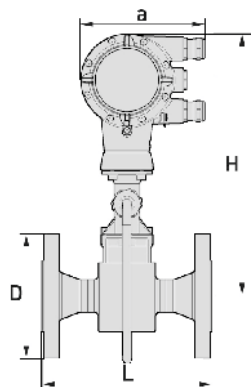

a = 148.5 mm / 5.85"

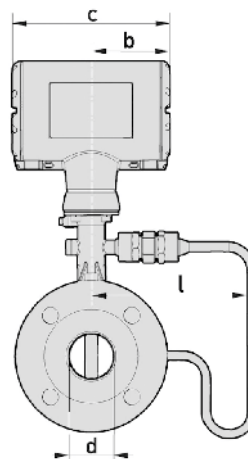

b = 85.8 mm / 3.38"
c = 171.5 mm / 6.76"

Dimensions of Flange Version ASME B16.5 (mm)

Nominal size DN	Pressure Rating Class	d	D	L	H	H F1R ①	H F2R ②	l	l F1R ①	l F2R ②
½	150	16	90	200	358.8	-	-	169.3	-	-
½	300	16	95	200	358.8	-	-	169.3	-	-
½	600	16	95	200	358.8	-	-	169.3	-	-
1	150	26.6	110	200	358.3	358.8	-	169.3	169.3	-
1	300	26.6	125	200	358.3	358.8	-	169.3	169.3	-
1	600	24	125	200	358.3	358.8	-	169.3	169.3	-
1 ½	150	41	125	200	362.3	358.3	358.8	169.5	169.3	169.3
1 ½	300	41	155	200	362.3	358.3	358.8	169.5	169.3	169.3
1 ½	600	41	155	200	362.3	358.3	358.8	169.5	169.3	169.3
2	150	52.5	150	200	368.3	362.3	358.3	169.5	169.5	169.3
2	300	52.5	165	200	368.3	362.3	358.3	169.5	169.5	169.3
2	600	49.2	165	200	368.3	362.3	358.3	169.5	169.5	169.3
3	150	77.9	190	200	380.3	368.3	362.3	169.3	169.5	169.5
3	300	77.9	210	200	380.3	368.3	362.3	169.3	169.5	169.5
3	600	74.0	210	200	380.3	368.3	362.3	169.3	169.5	169.5
4	150	102.3	230	250	396.8	380.3	368.3	171.5	169.3	169.5
4	300	102.3	255	250	396.8	380.3	368.3	171.5	169.3	169.5
4	600	97.0	275	250	396.8	380.3	368.3	171.5	169.3	169.5
6	150	154.1	280	300	416.3	396.8	380.3	191.5	171.5	169.3
6	300	154.1	320	300	416.3	396.8	380.3	191.5	171.5	169.3
6	600	146.0	355	300	416.3	396.8	380.3	191.5	171.5	169.3
8	150	202.7	345	300	442.1	416.3	396.8	202.8	191.5	171.5
8	300	202.7	380	300	442.1	416.3	396.8	202.8	191.5	171.5
10	150	254.6	405	380	468.8	442.1	416.3	229.5	202.8	191.5
10	300	254.6	455	380	468.8	442.1	416.3	229.5	202.8	191.5
12	150	300.0	485	450	442.8	468.8	442.1	255.0	229.5	202.8
12	300	300.0	520	450	442.8	468.8	442.1	255.0	229.5	202.8

① F1R - Single Reduction

② F2R - Double Reduction

Weight of Flange Version ASME B16.5 (kg)

Nominal size DN	Pressure Rating Class	with	without	F1R with	F1R without	F2R with	F2R without
		Pressure sensor		Pressure sensor		Pressure sensor	
1/2	150	5.1	4.5	-	-	-	-
1/2	300	5.5	4.9	-	-	-	-
1/2	600	5.7	5.1	-	-	-	-
1	150	6.8	6.2	6.6	6.0	-	-
1	300	7.8	7.2	7.6	7.0	-	-
1	600	8.1	7.5	7.9	7.3	-	-
1 1/2	150	8.9	8.3	8.6	8.0	7.7	7.1
1 1/2	300	11.0	10.4	10.9	10.3	10.0	9.4
1 1/2	600	12.0	11.4	11.8	11.2	11.0	10.4
2	150	11.6	11.0	11.0	10.4	10.3	9.7
2	300	13.0	12.4	12.6	12.0	11.9	11.3
2	600	14.5	13.9	14.0	13.4	13.4	12.8
3	150	20.4	19.8	16.9	16.3	15.6	15.0
3	300	23.4	22.8	20.4	19.8	19.2	18.6
3	600	24.4	23.8	22.9	22.3	21.8	21.2
4	150	24.0	23.4	25.3	24.7	22.7	22.1
4	300	32.0	31.4	33.9	33.3	31.2	30.6
4	600	41.0	40.4	44.1	43.5	41.2	40.6
6	150	36.8	36.2	37.8	37.2	36.9	36.3
6	300	51.8	51.2	56.1	55.5	55.8	55.2
6	600	76.8	76.2	79.8	79.2	82.6	82.0
8	150	50.6	50.0	48.8	48.2	52.5	51.9
8	300	75.4	74.8	72.2	71.6	78.1	77.5
10	150	75.0	74.4	75.2	74.6	73.9	73.3
10	300	107.0	106.4	112.4	111.8	113.5	112.9
12	150	107.0	106.4	109.8	109.2	120.4	119.8
12	300	152.0	151.4	165.4	155.8	171.7	171.1

Sandwich Version

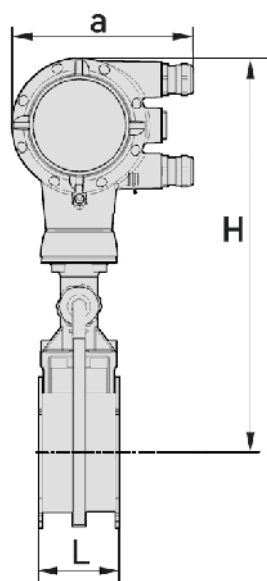

a = 133 mm / 5.24"

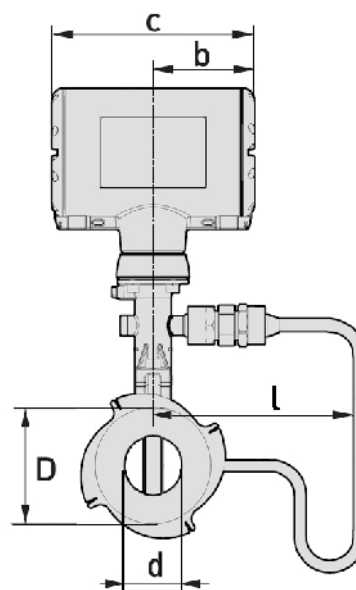

b = 105 mm / 4.13"

c = 179 mm / 7.05"

Sandwich Version ASME

Nominal Size	Pressure Rating	Dimensions [inch]					Weight [lb]		
		NPS	Class	d	D	L	H	l	with
								Pressure sensor	
½	150		0.63	1.77	2.56	14.13	6.67	9.04	7.72
½	300		0.63	1.77	2.56	14.13	6.67	9.04	7.72
½	600		0.55	1.77	2.56	14.13	6.67	9.04	7.72
1	150		0.94	2.56	2.56	14.13	6.67	10.8	9.48
1	300		0.94	2.56	2.56	14.13	6.67	10.8	9.48
1	600		0.94	2.56	2.56	14.13	6.67	10.8	9.48
1 ½	150		1.5	3.23	2.56	14.27	6.67	12.13	10.8
1 ½	300		1.5	3.23	2.56	14.27	6.67	12.13	10.8
1 ½	600		1.5	3.23	2.56	14.27	6.67	12.13	10.8
2	150		1.97	4.02	2.56	14.50	6.67	14.55	13.23
2	300		1.97	4.02	2.56	14.50	6.67	14.55	13.23
2	600		1.97	4.02	2.56	14.50	6.67	14.55	13.23
3	150		2.91	5.31	2.56	14.98	6.67	19.4	18.08
3	300		2.91	5.31	2.56	14.98	6.67	19.4	18.08
3	600		2.91	5.31	2.56	14.98	6.67	19.4	18.08
4	150		3.82	6.22	2.56	15.63	6.75	22.27	20.94
4	300		3.82	6.22	2.56	15.63	6.75	22.27	20.94
4	600		3.82	6.22	2.56	15.63	6.75	22.27	20.94

Dimensions of Remote Version

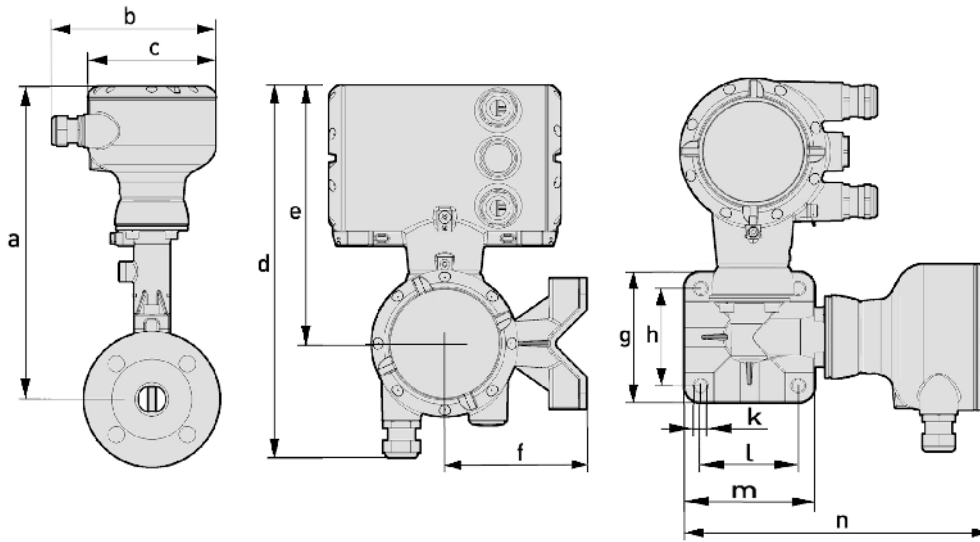

Dimension a

	Flange and Sandwich Version						Flange Version			
DN ▶	15	25	40	50	80	100	150	200	250	300
NPS ▶	½	1	1½	2	3	4	6	8	10	12
[mm] ▶	265.7	265.2	269.2	275.2	287.2	303.7	323.2	348.9	375.7	399.7
[inch] ▶	10.5	10.4	10.6	10.8	11.3	12.0	12.7	13.7	14.8	15.7

Dimension a F1/2R

DN	Flange Version									
	15	25	40	50	80	100	150	200	250	300
NPS	½	1	1½	2	3	4	6	8	10	12
F1R ① [mm]	-	315.7	315.2	319.2	325.2	337.2	353.7	373.2	398.9	425.7
F1R ① [inch]	-	12.4	12.4	12.6	12.8	13.3	13.9	14.7	15.7	16.8
F2R ② [mm]	-	-	315.7	315.2	319.2	325.2	337.2	353.7	373.2	398.9
F2R ② [inch]	-	-	12.4	12.4	12.6	12.8	13.3	13.9	14.7	15.7

① F1R - single reduction -② F2R - double reduction

Dimensions b...n

	b	c	d	e	f	g	h	j	k	l	m	n
[mm]	138.5	108.0	275.6	191.2	105.0	97.0	72.0	108.0	9.0	72.0	97.0	226.0
[inch]	5.46	4.25	10.9	7.53	4.14	3.82	2.84	4.25	0.35	2.84	3.82	8.90

Minimum Inlet Sections

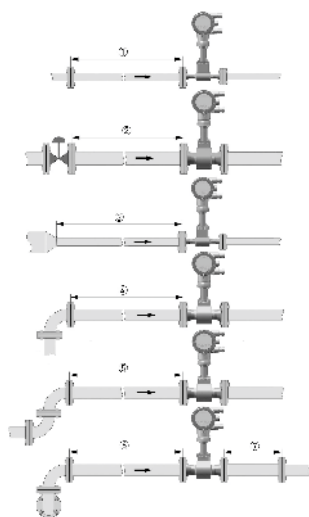

- ① General inlet section without disturbing flow ≥ 15 DN
- ② After a control valve ≥ 50 DN
- ③ After a pipe diameter reduction ≥ 20 DN
- ④ After a single bend $90^\circ \geq 20$ DN
- ⑤ After a double bend $2 \times 90^\circ \geq 30$ DN
- ⑥ After a double three-dimensional bend $2 \times 90^\circ \geq 40$ DN
- ⑦ Outlet section: > 5 DN

The nominal diameter of the flange is significant for the determination of the minimum inlet and outlet sections for the nominal diameter reduced versions of vortex flowmeter versions F1R and F2R.

Minimum Outlet Sections

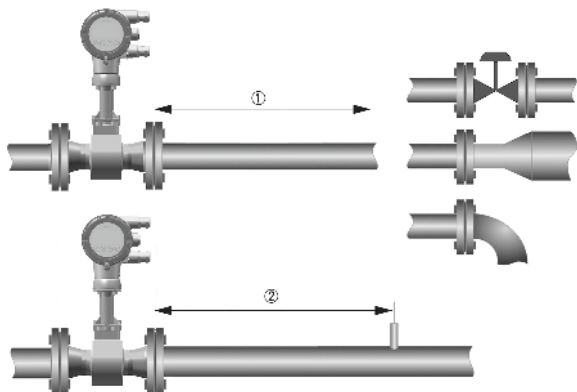

- ① Upstream of pipe expanders, pipe bends, control valves, etc. ≥ 5 DN
- ② Upstream of measuring points ≥ 5 DN

The interior of the pipe at the metering points must be free of burrs and other flow impediments.

The measuring device has an internal temperature sensor. The distance from external temperature measuring points must be ≥ 5 DN. Use flow sensors that are as short as possible to avoid disturbances of the flow profile.

Flow Straightener

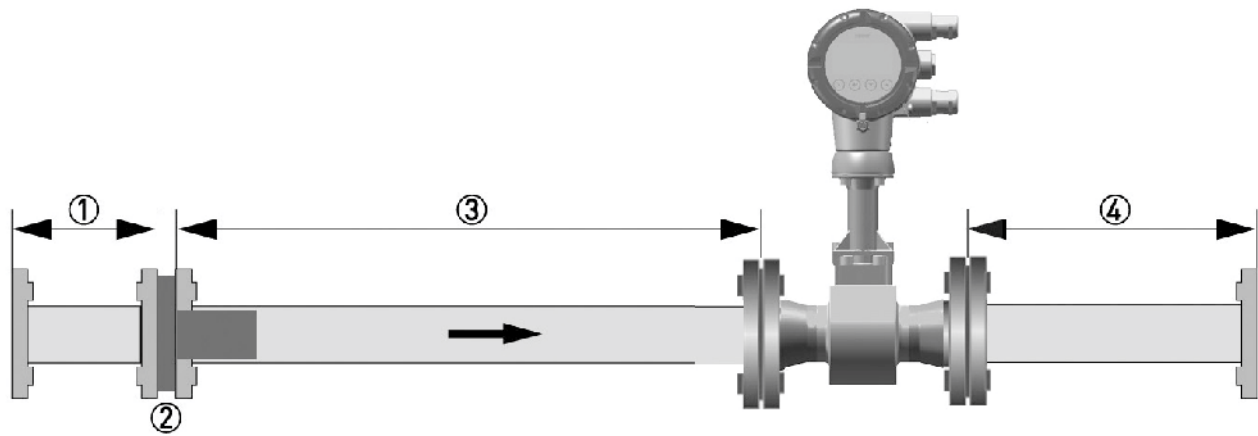

If, due to the type of installation, the required inlet sections are not available, the manufacturer recommends using flow straighteners. Flow straighteners are installed between two flanges upstream of the device and shorten the required inlet section.

- ① Straight inlet section upstream of straightener ≥ 2 DN
- ② Flow straightener
- ③ Straight pipe run between flow straightener and device ≥ 8 DN
- ④ Minimum straight outlet section ≥ 5 DN



Forbes Marshall
Krohne Marshall
Forbes Marshall Arca
Codel International
Forbes Solar
Forbes Vyncke
Forbes Marshall Steam Systems

Opp 106th Milestone
Bombay Poona Road
Kasarwadi, Pune - 411 034. INDIA
Tel : 91(0)20-27145595, 39858555
Fax : 91(0)20-27147413

Email : seg@forbesmarshall.com, ccmidc@forbesmarshall.com

© All rights reserved. Any reproduction or distribution in part or as a whole without written permission of Forbes Marshall Pvt Ltd, its associate companies or its subsidiaries ("FM Group") is prohibited.
Information, designs or specifications in this document are subject to change without notice. Responsibility for suitability, selection, installation, use, operation or maintenance of the product(s) rests solely with the purchaser and/or user. The contents of this document are presented for informational purposes only. FM Group disclaims liabilities or losses that may be incurred as a consequence of the use of this information.

B-85, Phase II, Chakan Indl Area
Sawardari, Chakan, Tal. Khed
Dist. Pune - 410 501. INDIA
Tel : 91(0)2135-393400

A-34/35, MIDC H Block
Pimpri, Pune - 411 018. INDIA.
Tel : 91(0)20-27442020, 39851199
Fax : 91(0)20-27442040

CIN No.: U28996PN1985PTC037806
www.forbesmarshall.com