

# COMBINATION SIGHT GLASS & CHECK VALVES

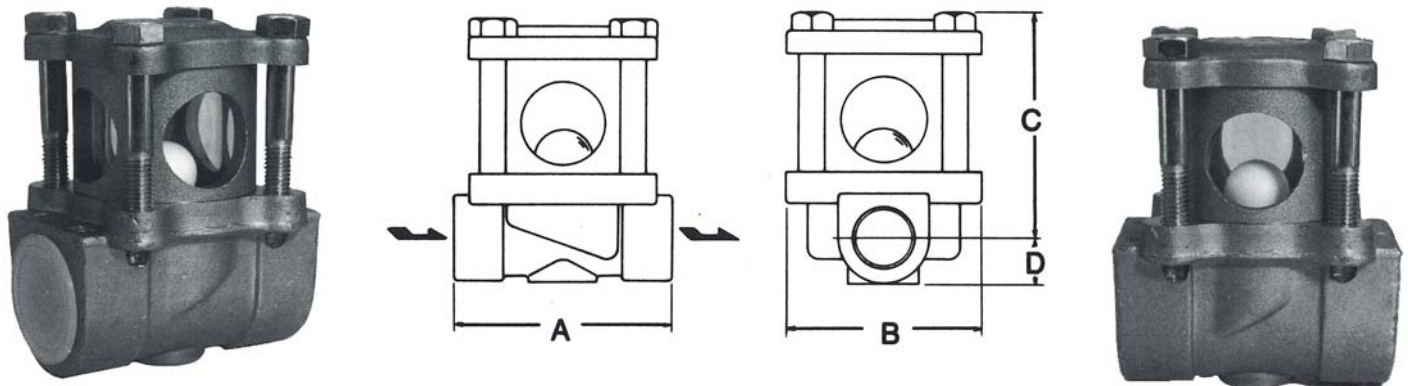

Model TS1

## APPLICATIONS

- The TS1 combination sight glass and check valve is ideally suited to detect leaking steam traps visually, without complicated sound or temperature measurement equipment.
- For installation in horizontal lines only.

## RATINGS

PMO (maximum operating pressure): 120 psi @ 350°F  
150 psi @ 212°F

## MATERIALS

Part	Material
Body	Forged Brass
Cover	Forged Brass
Window	Glass
Gaskets	Non-Asbestos
Ball	PTFE

## DIMENSIONS AND WEIGHTS

SIZE		A		B		C		D		Weight	
mm	in	mm	in	mm	in	mm	in	mm	in	kg	lbs
15	1/2	70	2-3/4	60	2-3/8	70	2-3/4	14	1/2	1	2-1/4
20	3/4	70	2-3/4	60	2-3/8	73	2-7/8	17	21/32	1	2-1/4
25	1	76	3	60	2-3/8	76	3	21	13/16	1.25	2-3/4

Colton has a policy of continuous product research and improvement and reserves the right to change design and specifications without notice



Tel: 1-888-300-9155 Fax: 1-888-300-9160 www.COLTONIND.com info@coltonind.com

BULLETIN SP500-1