

Donaldson® DF filter housings are designed for high quality filtration of compressed air or gas in a wide range of applications.

The filter design combines high performance, greater efficiency, ease of use, flexibility, and safety.

- *High performance* — the flow-optimized filter design, paired with innovative filtration technology, reduces pressure loss by 50% compared to conventional filters.
- *Safety* — the unique bayonet lock ensures that the filter cannot be opened under pressure for increased safety.
- *Energy savings* — you will find that greater energy savings are achieved through timely filter element replacement. Element change out is determined by the Economizer that continuously measures the differential pressure. An integrated microprocessor evaluates the measured data and compares the higher energy costs caused by pressure loss with the costs of a new filter element.



DF Series

FEATURES	BENEFITS
Multiple housing sizes, element types and accessories	Allows for unique and specialized solutions for each application
Optimized flow design — reduced pressure drop by 50%	Minimum pressure loss means lower energy consumption compared to conventional filters
Performance data is validated according to ISO 12500-1	Reliable filtration of compressed air according to ISO 8573-1
Filter element can be removed together with filter bowl	Minimizes space needed for filtration installation
Code clip inside the filter bowl can be changed for multiple flow directions through the element	Dual use housings can be used either as a coalescing filter (inside to outside flow) or a particulate filter (outside to inside flow)
Bayonet filter bowl lock - filter cannot be opened under pressure	Increased safety
Integrated differential pressure indicator	Allows user to replace filter element at the proper interval
Immersion-coated housing	Long-term protection against corrosion

SPECIFICATIONS

MATERIALS		DESIGN PRESSURE AND TEMPERATURE
Filter Housing	Aluminum die cast	250 psig @ 150°F
Differential Pressure	DF Standard: Econometer DF SuperPlus: Economizer	
Float Drain	DF Standard: polymer/aluminum mold cast (Note: DF1100 MK comes with UFM-P drain valve) DF SuperPlus: Aluminum, glass fiber reinforced polymer	
Housing Bowl Gasket	Buna	

CAPACITY CORRECTION FACTORS

Operating Pressure (psig)	15	30	45	60	75	90	100	115	130	150	160	175	190	200	220	230
Correction Factor	0.3	0.4	0.5	0.6	0.8	0.9	1.0	1.1	1.2	1.4	1.5	1.6	1.8	1.9	2.0	2.1

DIMENSIONS

Model	Capacity ¹ (scfm)	Connection (FNPT)	Element		Dimensions (inches)				Weight (lbs)	
					Standard		SuperPlus		Standard ²	SuperPlus ²
			Size	Qty	Height A	Width I	Height A	Width J		
DF 0035	20	1/4"	0035	1	7.5	3.5	16	3.5	1	3
DF 0070	41	3/8"	0070	1	11.5	4.5	18	4.5	2	4
DF 0120	70	1/2"	0120	1	13.5	4.5	20	4.5	2	4
DF 0210	123	3/4"	0210	1	14.5	6	21	6	5	6
DF 0320	188	1"	0320	1	17.5	6	24	6	5	7
DF 0450	264	1-1/4"	0450	1	23	7.5	29	7.5	12	7
DF 0600	353	1-1/2"	0600	1	23	7.5	31	7.5	12	7
DF 0750	441	2"	0750	1	23	7.5	31	7.5	12	7
DF 1100	647	2"	1100	1	30	7.5	35	7.5	16	15

¹ Capacity based on 100 psig inlet pressure.

² Without filter element.

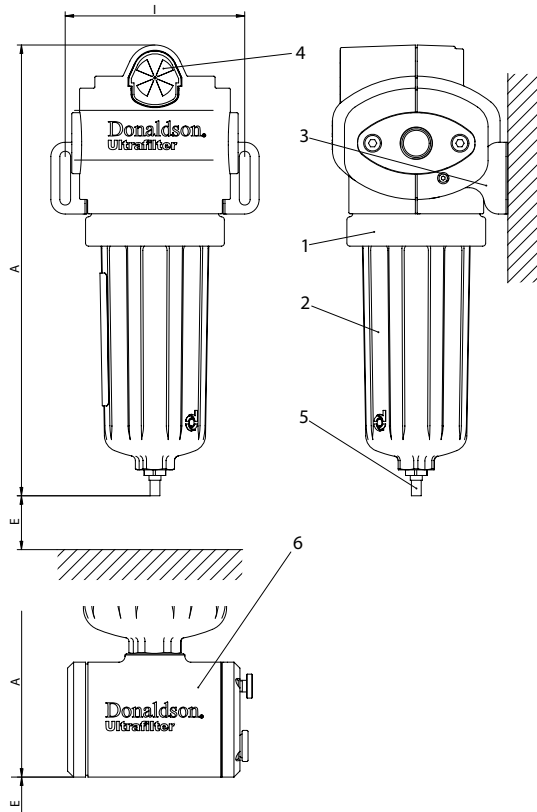

DF Standard

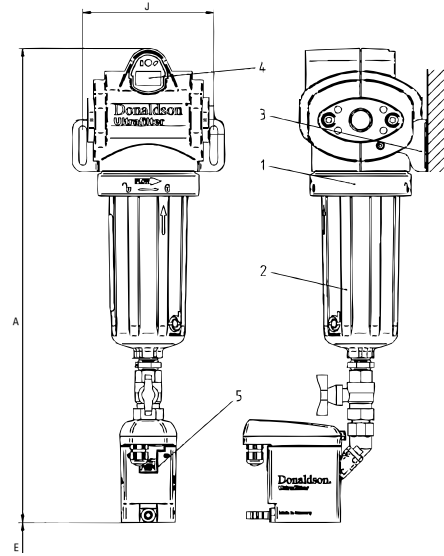

DF SuperPlus

No.	Qty	Description
1	1	Filter head
2	1	Lower housing bowl
3	2	Wall bracket (option)
4	1	Econometer
5	1	Internal automatic drain KA 1/2
6	1	External automatic drain UFM-P (optional)

No.	Qty	Description
1	1	Filter head
2	1	Lower housing bowl
3	2	Wall bracket (option)
4	1	Economizer
5	1	Condensate UFM-D03 (DF 0035 - DF 1100)

PERFORMANCE DATA

Type	Element & Housing		Element Only		Residual Oil Content	Particle Retention Rate
	Initial Δp (psid) Dry	Initial Δp (psid) Wet	Initial Δp (psid) Dry	Initial Δp (psid) Wet		
P Particle Filter	2.17	2.90	1.08	1.81	NA	25 micron absolute
B Particulate Filter	1.74	NA	0.50	NA	NA	25 micron absolute
V Coalescing Filter	1.60	1.74	0.50	0.65	1 ppm	99.9% on 5 micron particles
M UltraPleat™ Coalescing Filter	1.09	2.03	0.50	1.52	1 ppm	99.9999% on 0.01 micron particles
S UltraPleat™ Coalescing Filter	1.45	2.61	0.64	2.00	<0.003 ppm	99.99998% on 0.01 micron particles
A Carbon Filter	1	NA	0.79	NA	<0.003 ppm	1 micron absolute



Important Notice

Many factors beyond the control of Donaldson can affect the use and performance of Donaldson products in a particular application, including the conditions under which the product is used. Since these factors are uniquely within the user's knowledge and control, it is essential the user evaluate the products to determine whether the product is fit for the particular purpose and suitable for the user's application. All products, specifications, availability and data are subject to change without notice, and may vary by region or country.



Donaldson Company, Inc.
Minneapolis, MN

donaldson.com
shop.donaldson.com

Australasia 61-02-4350-2066
marketing.australia@donaldson.com

Brazil 55-11-4894-6035
vendas.brasil@donaldson.com

China 86-400-921-7032
info.cn@donaldson.com

EMEA 49-2129-569-0
cap-europe@donaldson.com

India 91-124-4807-400
indiaenquiries@donaldson.com

Japan 81-42-540-4123
ndi-ultrafilter-web@donaldson.com

Korea 82-2-517-3333
cap-kr@donaldson.com

Latin America 52-449-300-2442
industrialair@donaldson.com

North America 800-543-3634
processfilters@donaldson.com

South Africa 27-11-997-6000
samarketing@donaldson.com

Southeast Asia 65-6311-7373
sea.salesenquiry@donaldson.com

F117033 ENG (05/19) DF Series Compressed Air Filter Housings

© 2007 Donaldson Co., Inc. All Rights Reserved. Donaldson and the color blue are marks of Donaldson Company, Inc. All other marks belong to their respective owners.
{Contains Donaldson proprietary technology.}