

Stainless steel gas/steam filter housings.

Donaldson® P-EG filter housings are designed for purification of compressed air, technical gases and steam. They are equipped with NPT thread or flange connections depending on size and have an electro-polished or bead-blast surface finish. P-EG filter housings are designed to yield low differential pressure at high flow rates.

P-EG filter housings are available in 18 different sizes with a capacity range from 35 to 12,700 scfm at 100 psig. Optional connections are also available to adapt the filter to your specific requirements. Standard housings utilize Donaldson filter elements with two-inch, double O-Ring, plug-in connections.

A broad selection of filter elements is available to meet the compatibility and micron rating requirements of your process.



P-EG

MATERIALS	
Filter Housing	304 SS 316L SS (on request)
Sealing Nut	304 SS
Plug	304 SS/PTFE gasket
Housing Gasket	EPDM (other gaskets available upon request)

DESIGN PRESSURE AND TEMPERATURE	
FNPT Housings (0006-0192)	232 psig @ 392°F
FNPT Housing (0288)	174 psig @ 392°F
ANSI Flange Housings (0027-0192)	232 psig @ 302°F
ANSI Flange Housing (0288)	174 psig @ 302°F
ANSI Flange Housings (0432-1920)	150 psig @ 450°F

SURFACE FINISH	
Inner	
0006-0288	Pickled and passivated to Ra 63
0432-1920	Bead blast
Outer	
0006-0288	Pickled, passivated, and polished Ra 63
0432-1920	Bead blast

CONNECTION TYPES
NPT thread connection (standard for 0006-0288 single element housing)
ANSI Flange (standard for 0432-1920; optional up to 0288)
Welded End (optional)
Other connections and bigger housings are available on request

DIMENSIONS

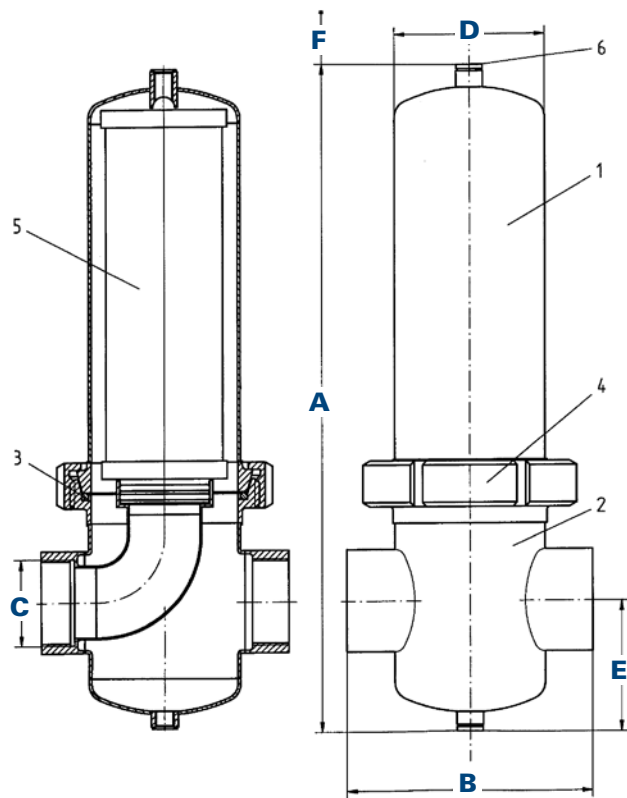

With thread connection

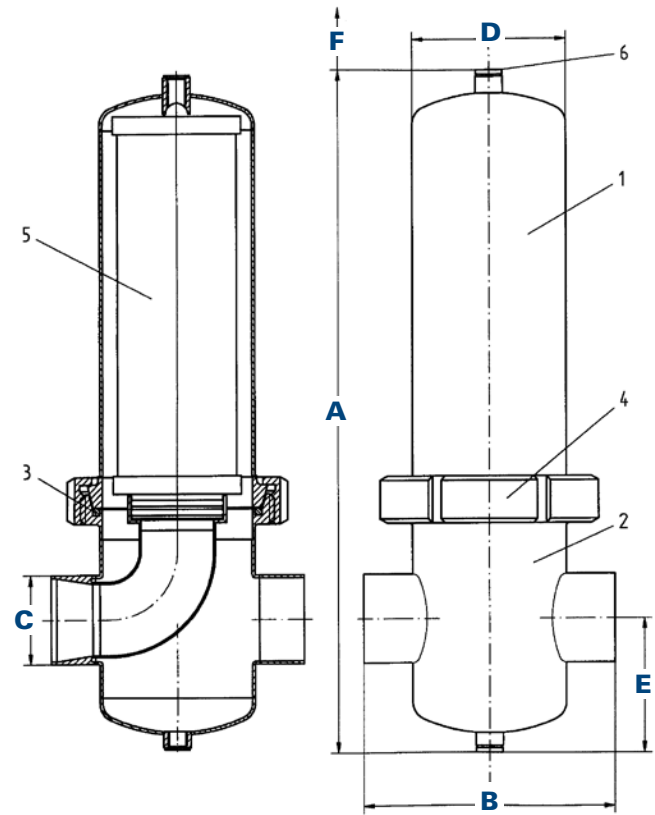

With butt weld end

No.	Qty	Description
1	1	Upper housing bowl
2	1	Lower housing bowl
3	1	Housing gasket

No.	Qty	Description
4	1	Sealing nut
5	1	Filter element
6	2	Plug

Size	Volume (gal)	Weight* (lbs)	Dimensions (inches)							Element Size
			A	B ± .125	C		D	E	F	
					w/NPT thread connection	w/butt weld end				
0006	0.1	4	8.31	4.17	0.25	0.375	2.76	2.01	4	03/10
0009	0.2	4	9.57	4.29	0.375	0.375	2.76	2.09	5	04/10
0012	0.2	4	9.43	4.29	0.50	0.50	2.76	2.01	5	04/20
0018	0.2	4	10.35	4.92	0.75	0.75	2.76	2.01	6	05/20
0027	0.3	6	11.40	4.92	1.00	1.00	3.35	2.80	6	05/25
0036	0.3	7	13.19	5.51	1.25	1.25	3.35	2.64	8	07/25
0048	0.6	9	14.88	6.69	1.50	1.50	4.09	3.50	8	07/30
0072	0.9	11	17.76	6.69	2.00	2.00	4.09	3.50	11	10/30
0108	1.1	12	22.81	6.69	2.00	2.00	4.09	3.50	18	15/30
0144	2.1	20	28.48	8.50	2.50	2.50	5.08	3.90	23	20/30
0192	2.9	24	38.71	8.50	3.00	3.00	5.08	4.04	33	30/30
0288	4.4	36	40.72	9.45	3.00	3.00	6.06	4.32	33	30/50

* Without filter element

DIMENSIONS

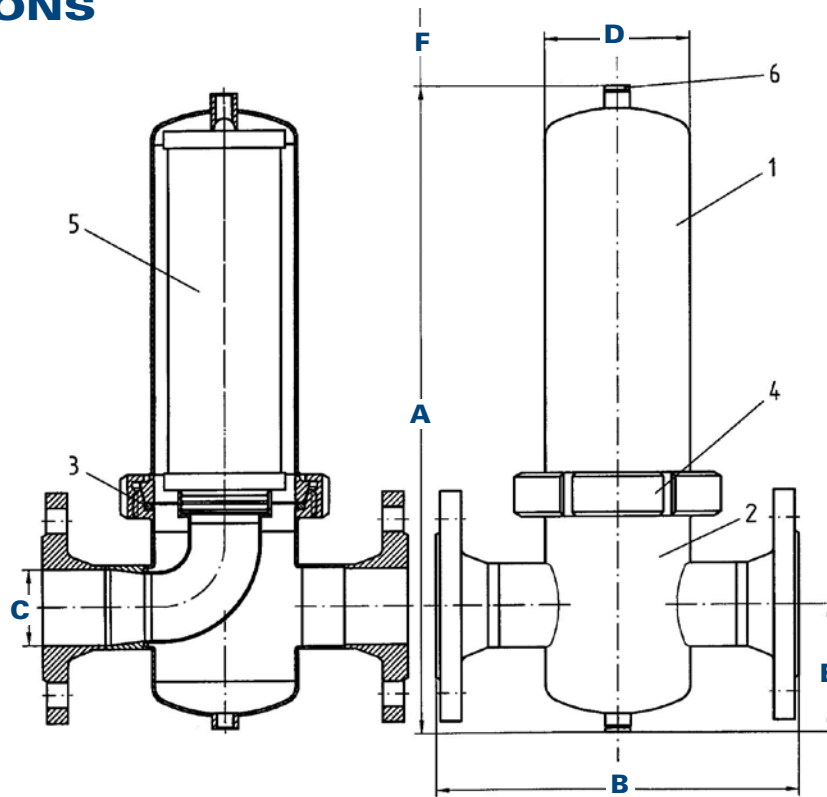

With flange connection ANSI 150 lb

No.	Qty	Description
1	1	Upper housing bowl
2	1	Lower housing bowl
3	1	Housing gasket

No.	Qty.	Description
4	1	Sealing nut
5	1	Filter element
6	2	Plug

Size	Volume (gal)	Weight* (lbs)	Dimensions (inches)						Element Size
			A	B ± .125	C**	D	E	F	
0006	0.1	6	8.5	8.00	0.50	3	2	4	03/10
0009	0.2	6	9.5	8.00	0.50	3	2	5	04/10
0012	0.2	4	9.19	8.00	0.50	2.76	1.87	5	04/20
0018	0.2	8	10.13	9.06	0.75	2.76	1.87	6	05/20
0027	0.3	11	11.0	9.69	1.00	3.35	2.60	6	05/25
0036	0.3	14	13.19	10.02	1.25	3.35	2.64	8	07/25
0048	0.6	18	14.87	11.57	1.50	4.09	3.50	8	07/30
0072	0.9	22	17.80	11.69	2.00	4.09	3.50	11	10/30
0108	1.1	23	22.80	11.69	2.00	4.09	3.50	18	15/30
0144	2.1	33	28.55	13.38	2.50	5.08	3.90	23	20/30
0192	2.9	40	38.86	13.38	3.00	5.08	4.06	33	30/30
0288	4.4	52	40.01	14.95	3.00	6.06	4.33	33	30/50

* Without filter element
 ** 150 lbs ANSI B16.5

DIMENSIONS

No.	Description
1	Upper housing bowl
2	Lower housing bowl
3	Hexagon bolt
4	Washer
5	Nut
6	Gasket
7	Bracket bolt
8	Bracket plate
9	Tie rod
10	Filter element
11	Plug
12	Lifting eye bolts
13	Spring

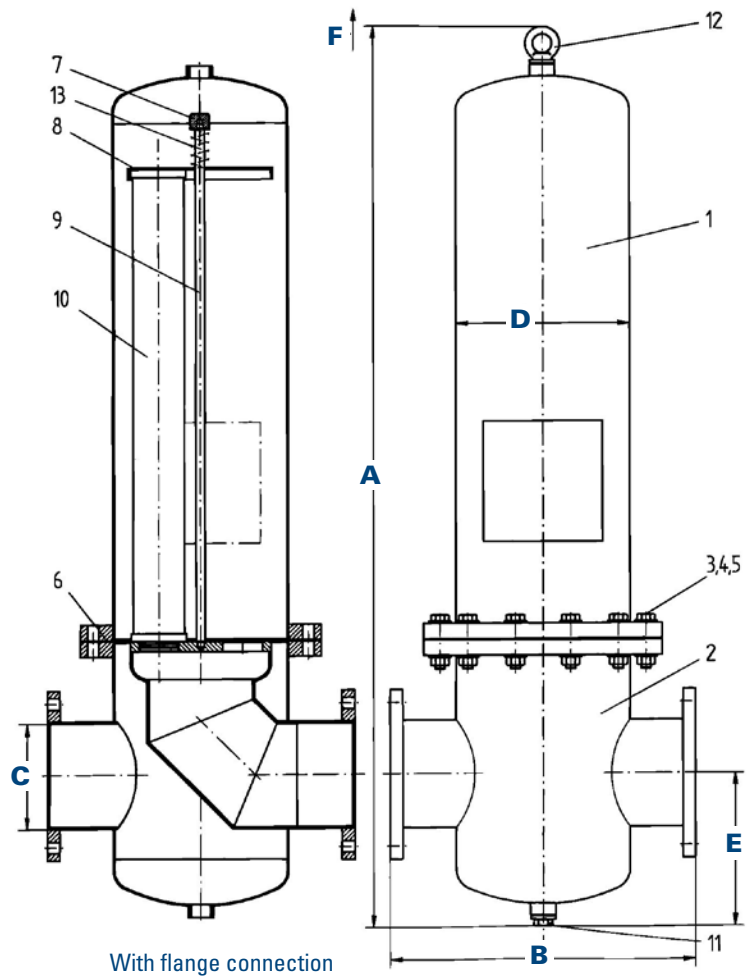

Size	Volume (gal)	Weight* (lbs)	Dimensions (inches)						Qty	Element Size
			A	B (± .125)	C**	D	E	F		
0432	9.5	140	36.66	16.14	4	8.62	7.25	23	3	20/30
0576	11.9	183	46.66	16.14	4	8.62	7.25	33	3	30/30
0768	20.3	220	53.13	18.90	6	10.75	9.00	33	4	30/30
1152	29.1	338	54.79	21.26	6	12.75	8.82	33	6	30/30
1536	50.2	628	62.63	26.00	8	16.0	15.82	33	8	30/30
1920	50.2	628	60.50	25.98	8	16.0	13.87	33	10	30/30

* Without filter element
 ** 150 lbs ANSI B16.5

Important Notice

Many factors beyond the control of Donaldson can affect the use and performance of Donaldson products in a particular application, including the conditions under which the product is used. Since these factors are uniquely within the user's knowledge and control, it is essential the user evaluate the products to determine whether the product is fit for the particular purpose and suitable for the user's application. All products, specifications, availability and data are subject to change without notice, and may vary by region or country.



Donaldson Company, Inc.
 Process Filtration
 PO Box 1299
 Minneapolis, MN
 55440-1299 U.S.A.

Tel 800-543-3634 (USA)
 Tel 800-343-3639 (within Mexico)
 Fax 952-885-4791
 processfilters@donaldson.com
 donaldsonprocessfilters.com



F117000 (11/17) ENG P-EG Gas/Steam Filter Housings

© 2007 Donaldson Co., Inc. All Rights Reserved. Donaldson and the color blue are marks of Donaldson Company, Inc. All other marks belong to their respective owners.
 {Contains Donaldson proprietary technology.}